

# MSM 16J3

## Assembly Instructions

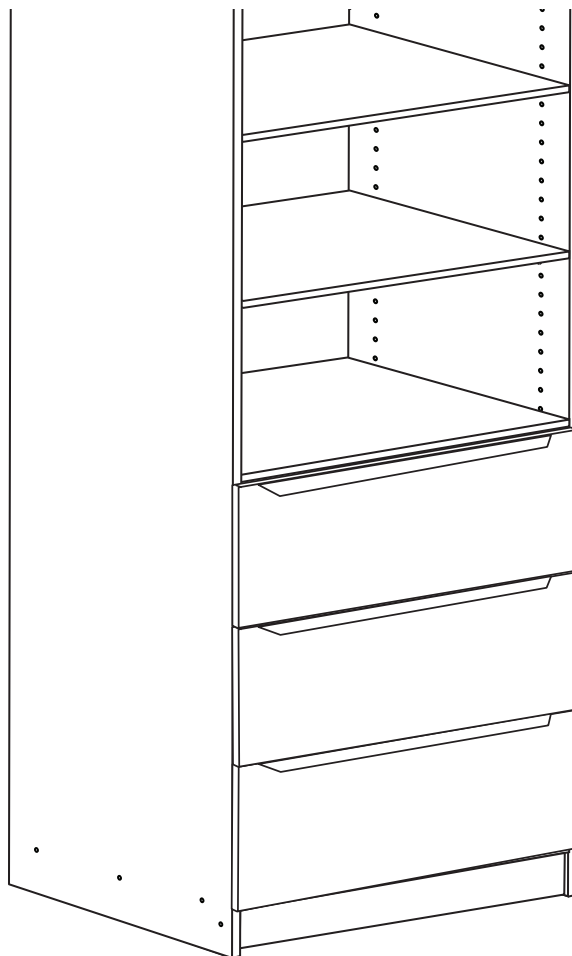



Thank you for choosing Multistore for your home. All the information you need to assemble your product is in this guide. However, if you need further support visit [multistore.com.au](http://multistore.com.au) for video installs.



Share your project photos with us  
@MultistoreSolutions



Your warranty details are at the back of this guide.

**WARNING:** Serious injury or death can be caused by toppling furniture. Attach unit to wall using safety bracket provided. Fix bracket in middle of unit with 16mm screw. Fix to wall stud using 25mm screw. For other wall types use suitable fixings (not provided).

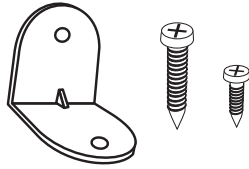

**All you need:**

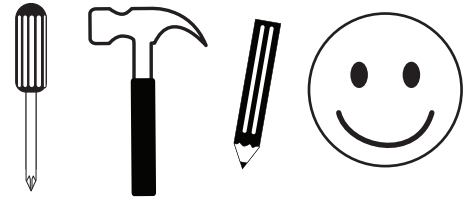

## Shell

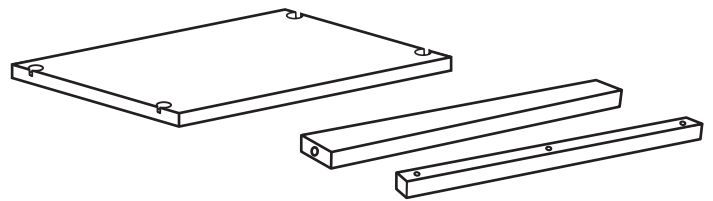
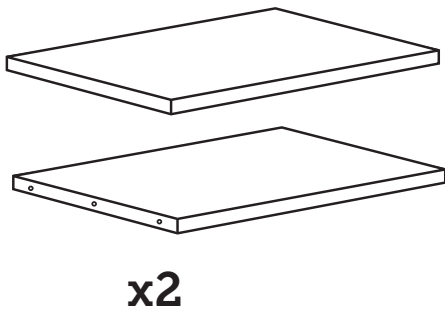
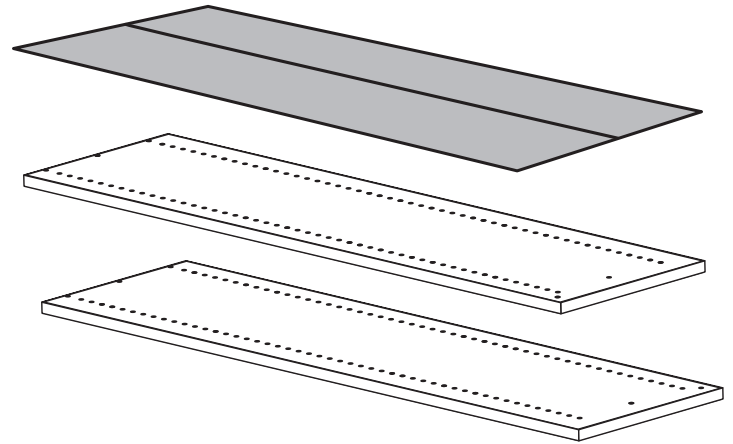
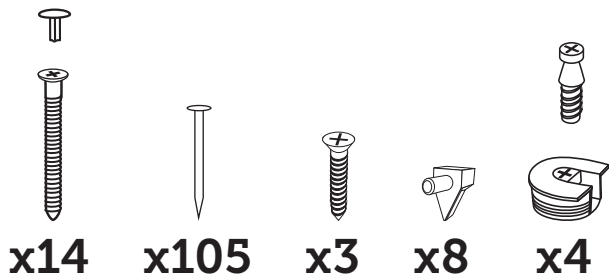

## Drawer

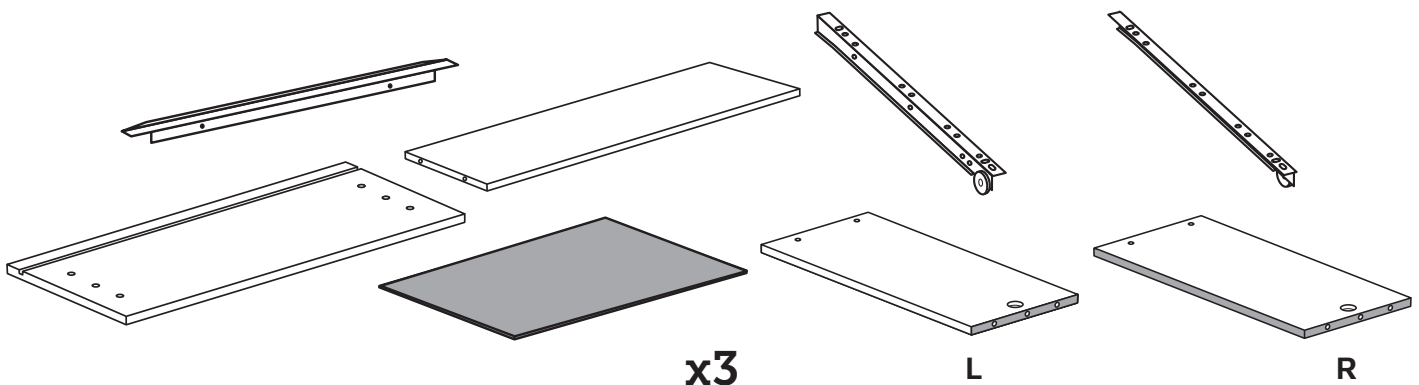
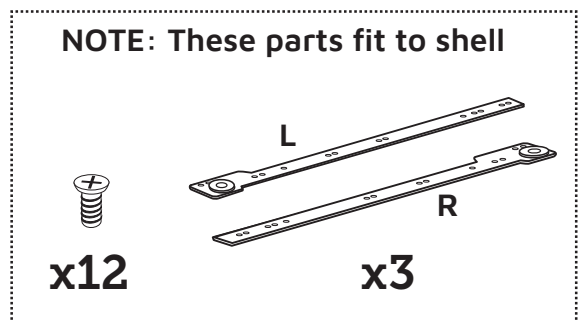
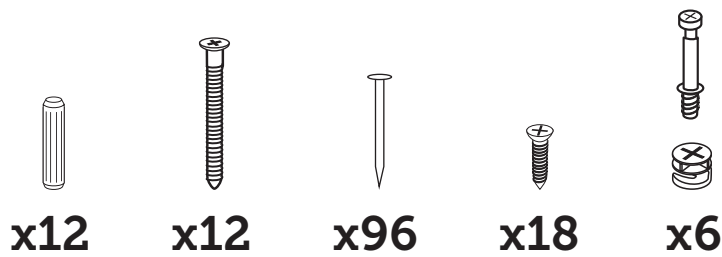

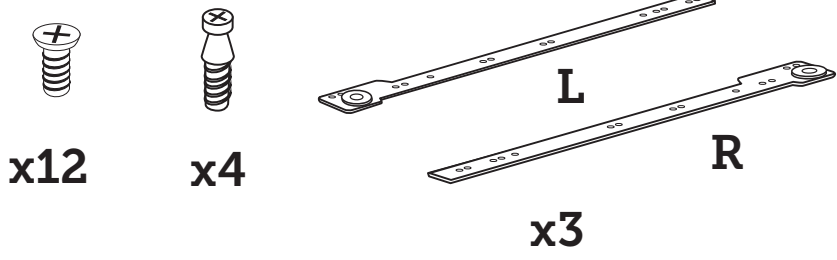

# 1

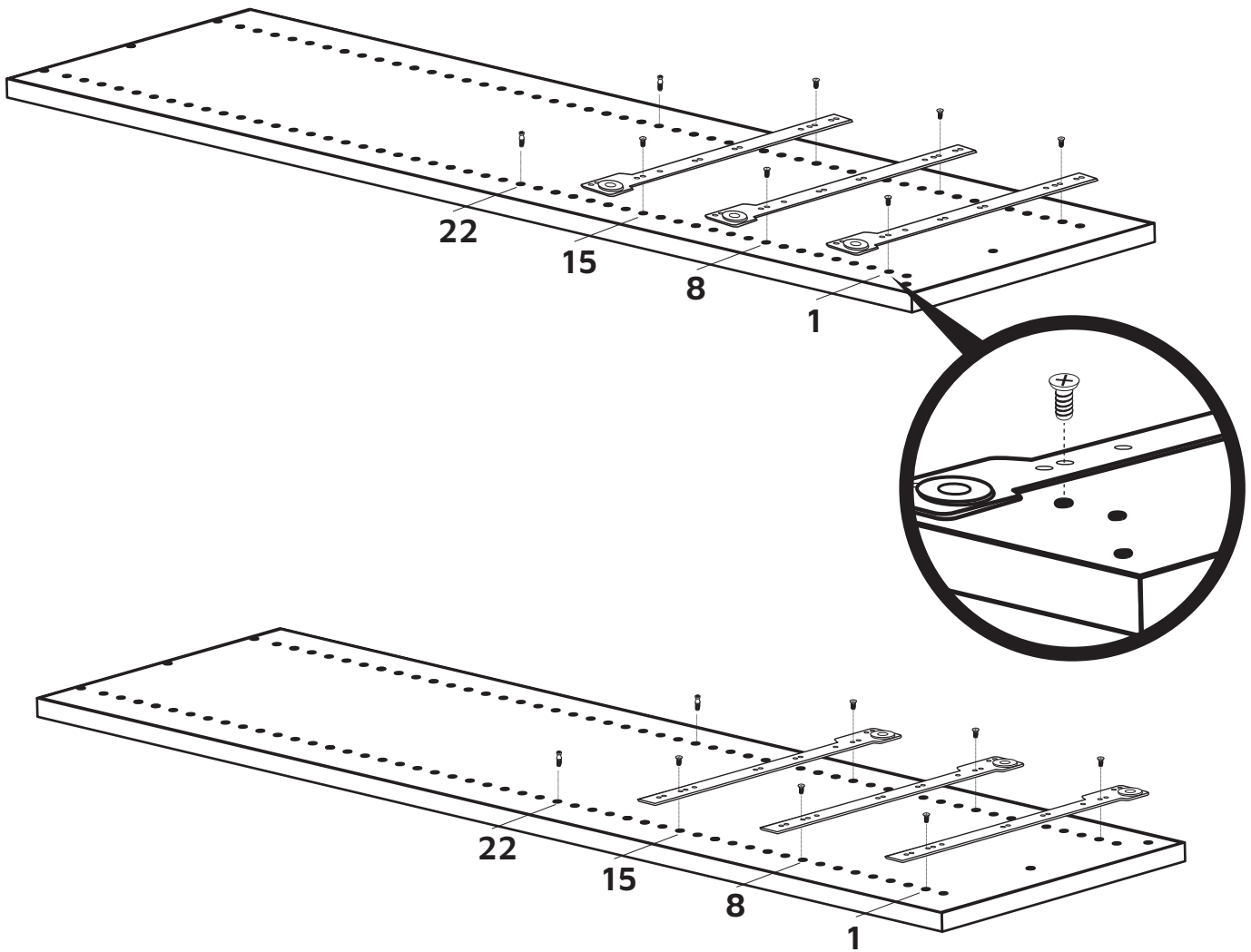



x4

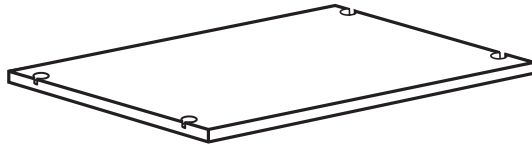

# 2

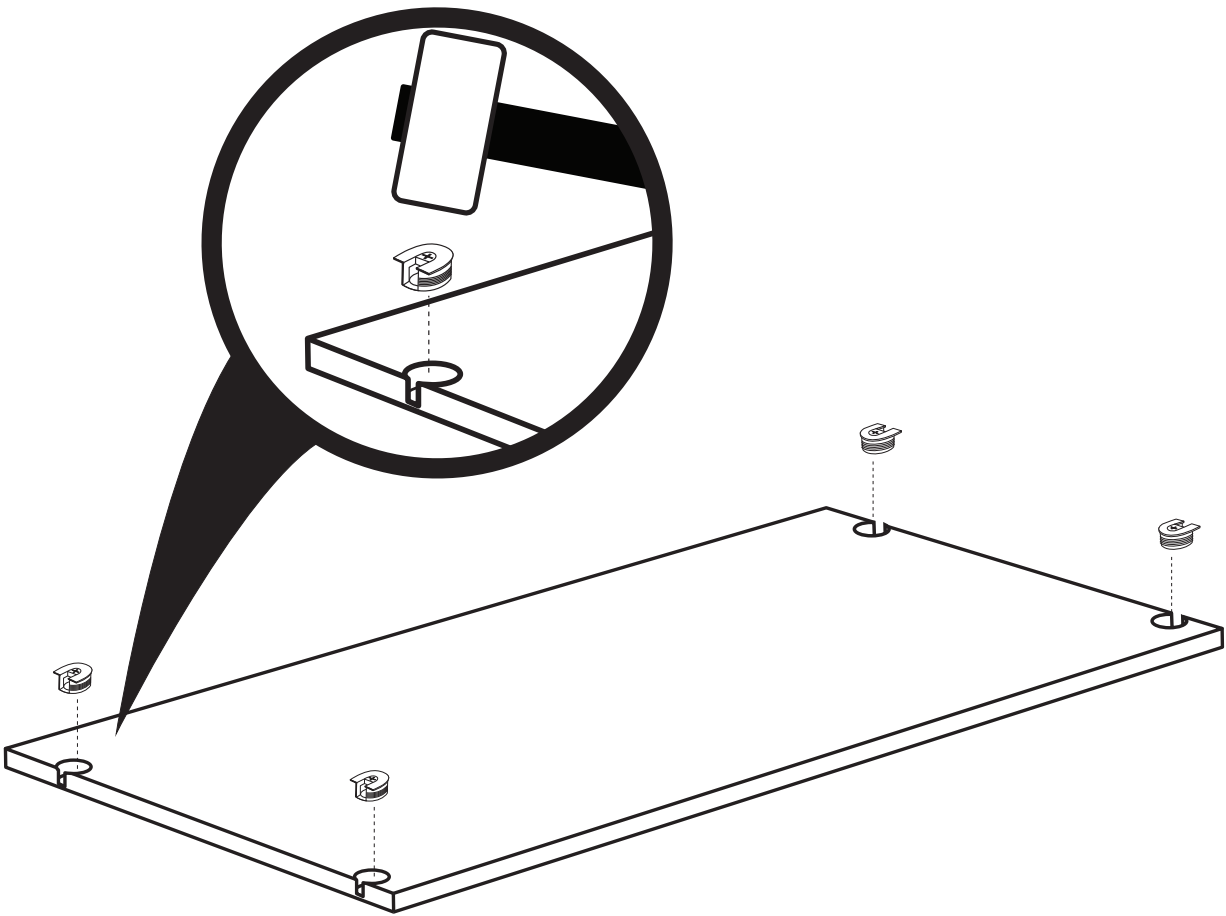



x14

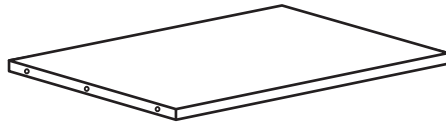

x2



# 3

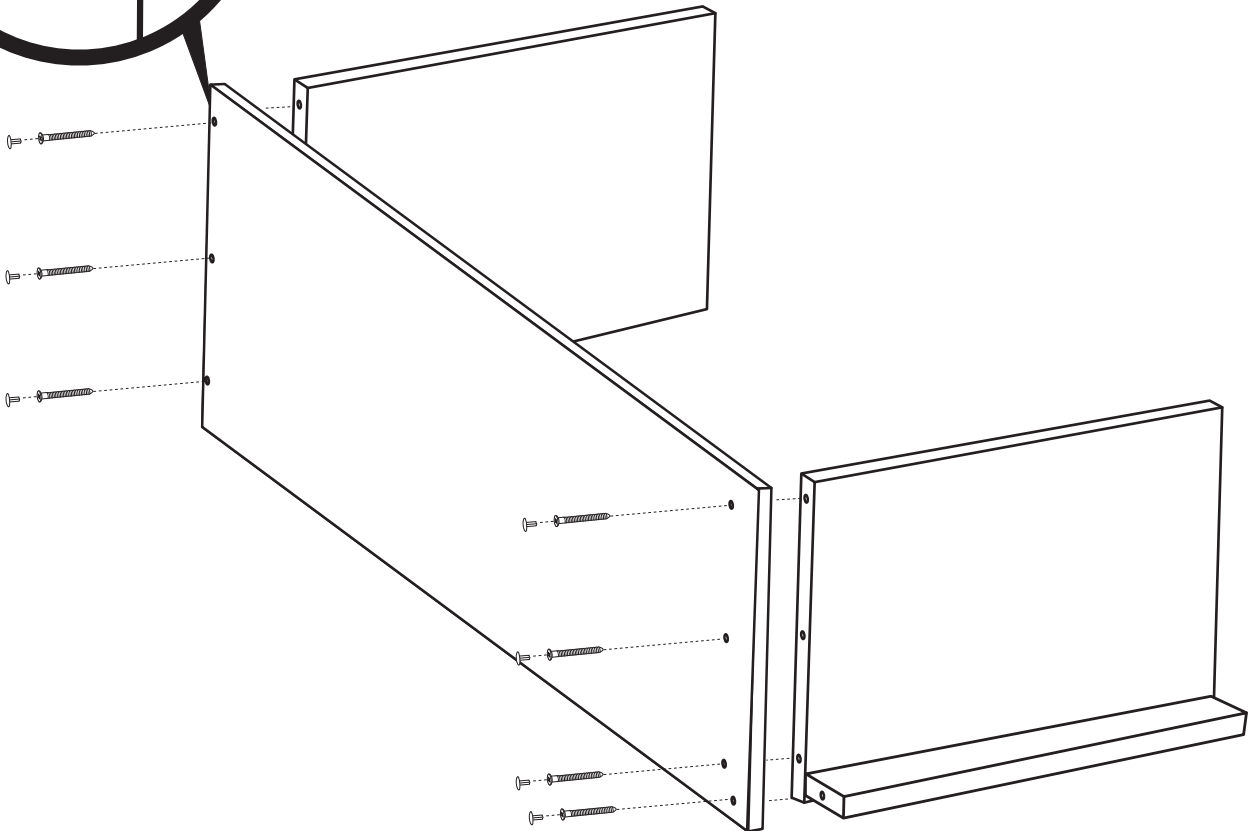
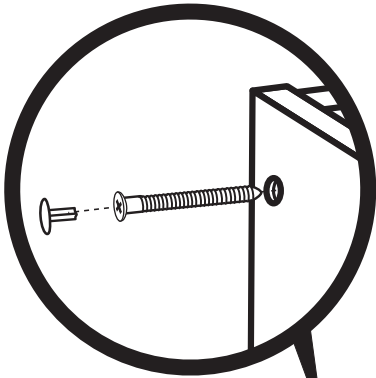
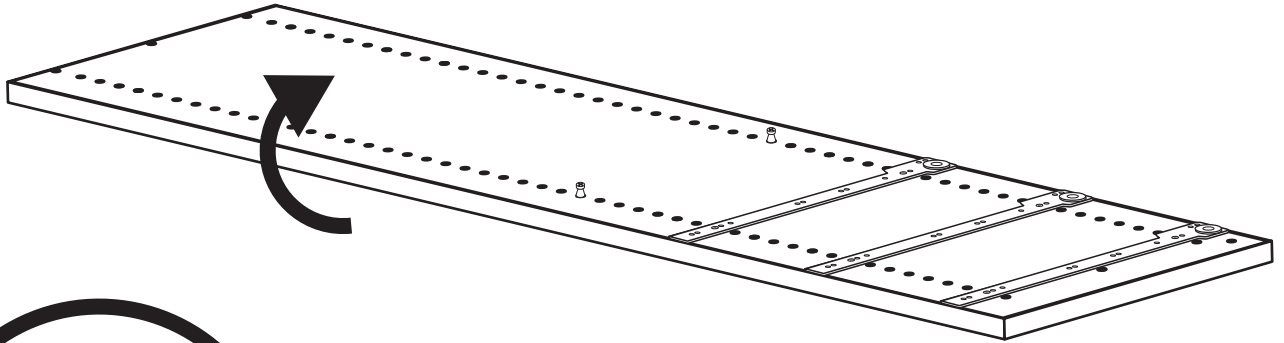

# 4

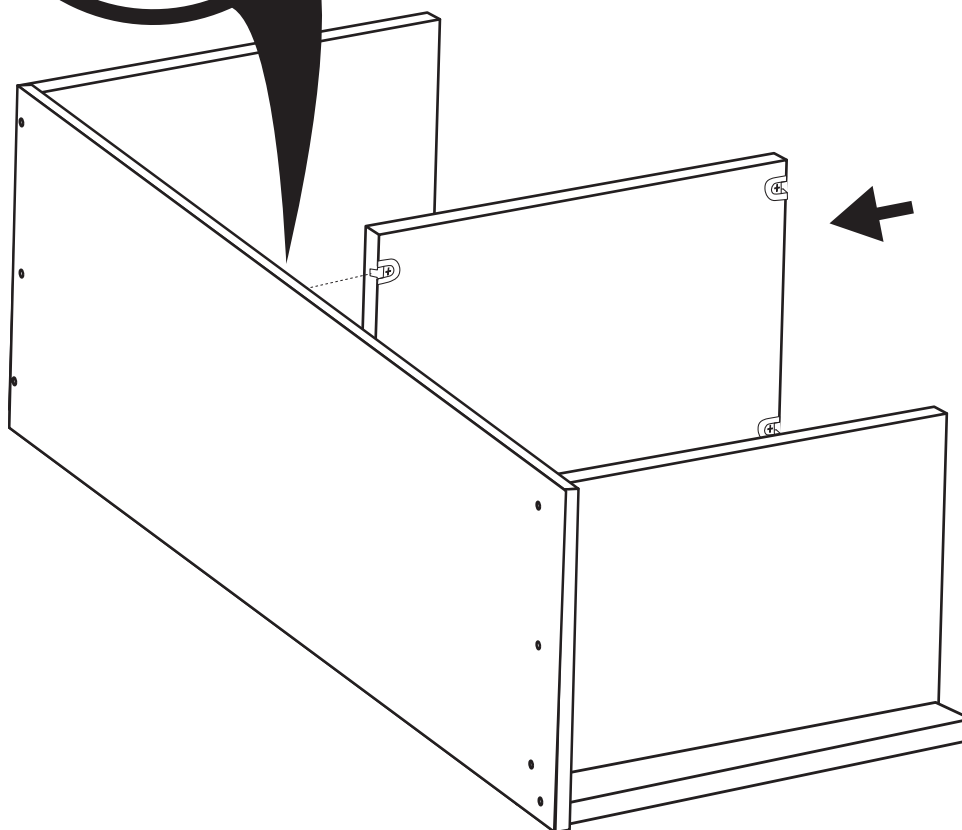
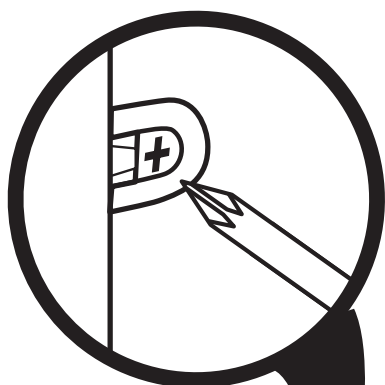
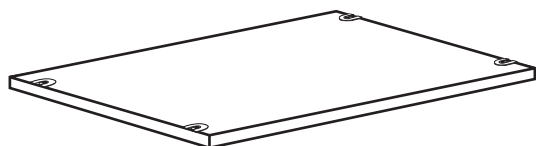

# 5

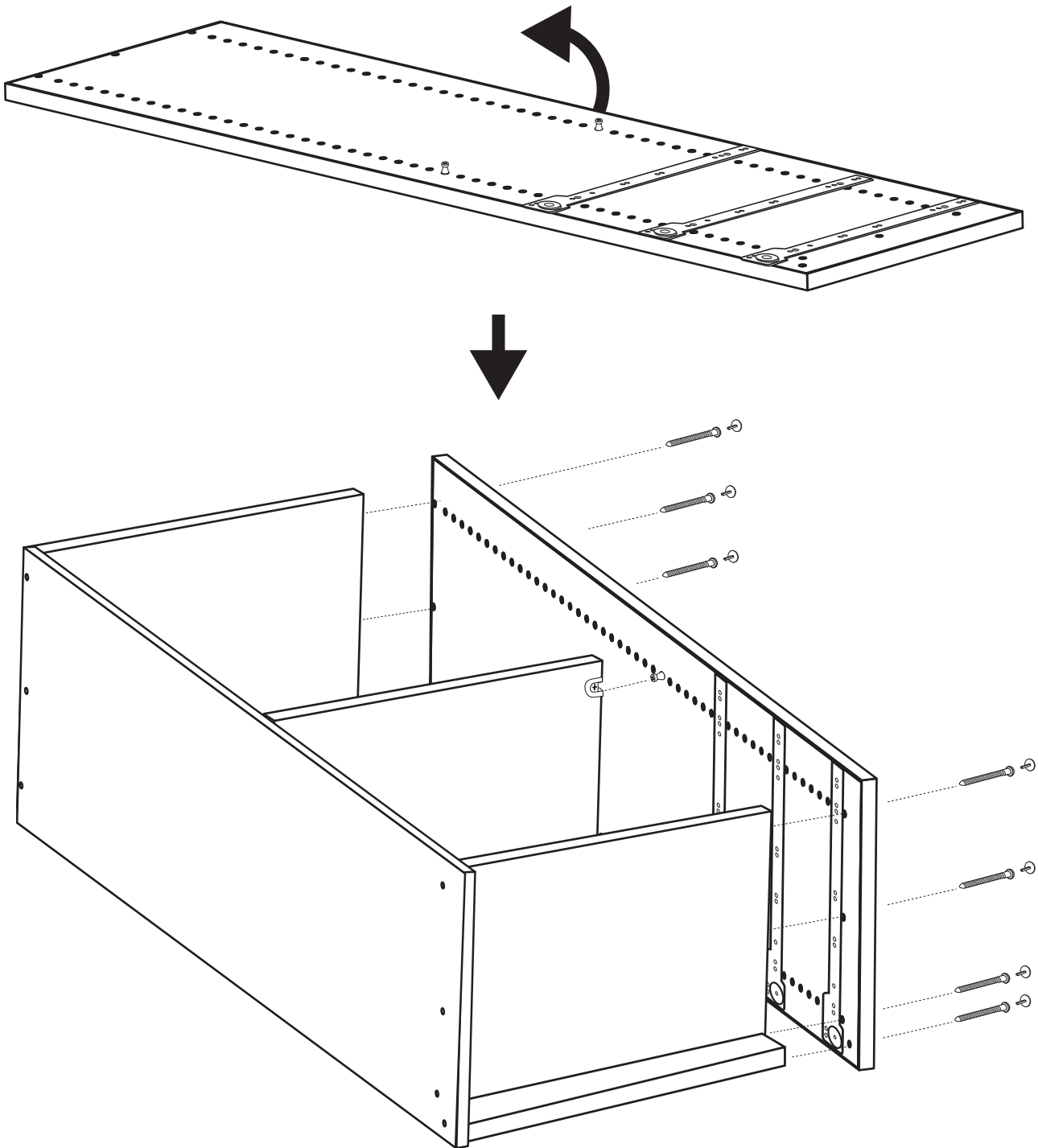





x105

6

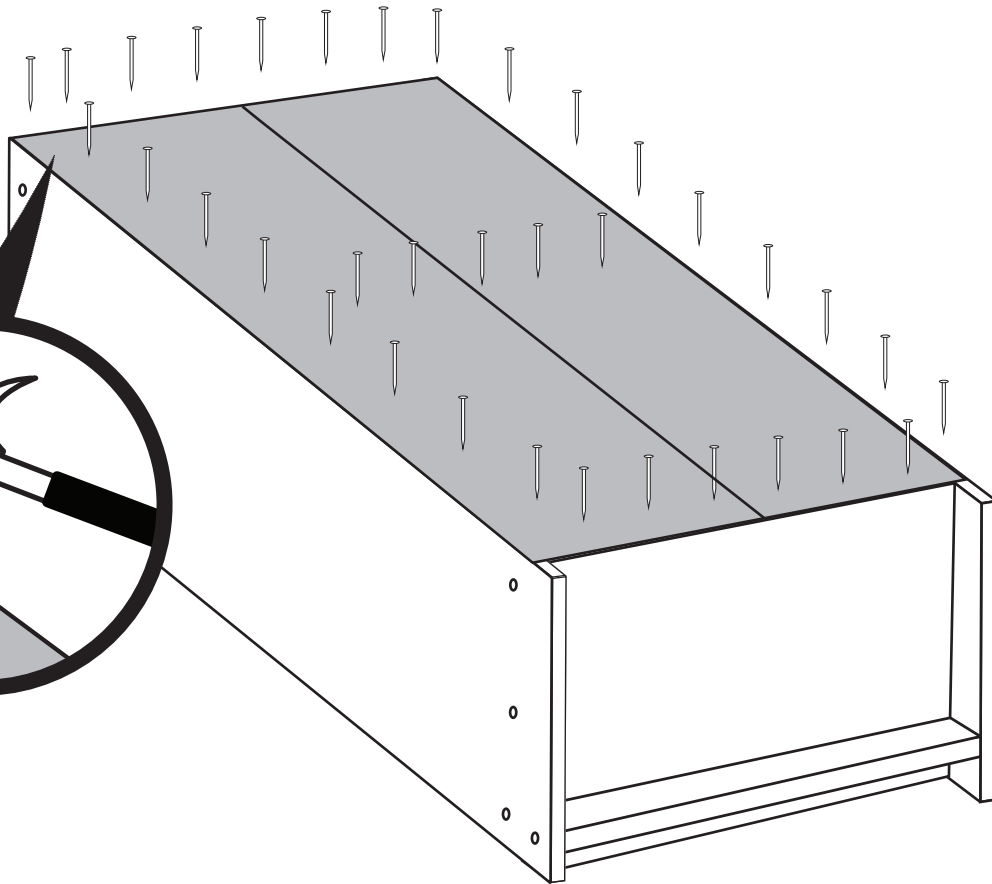
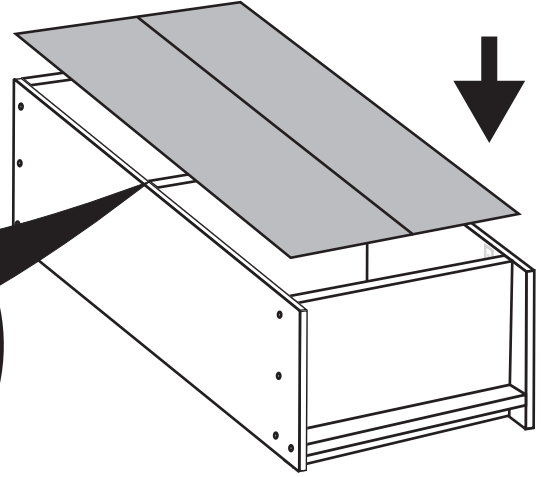
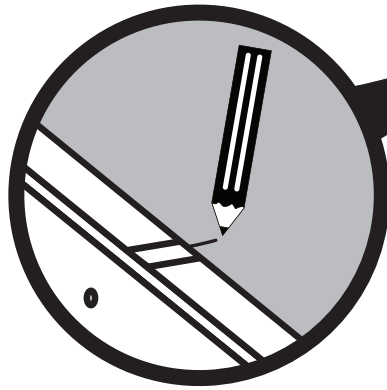

 x3

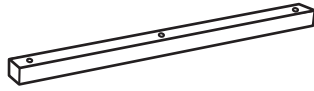

# 7

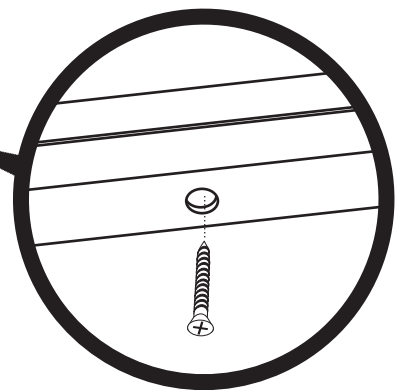
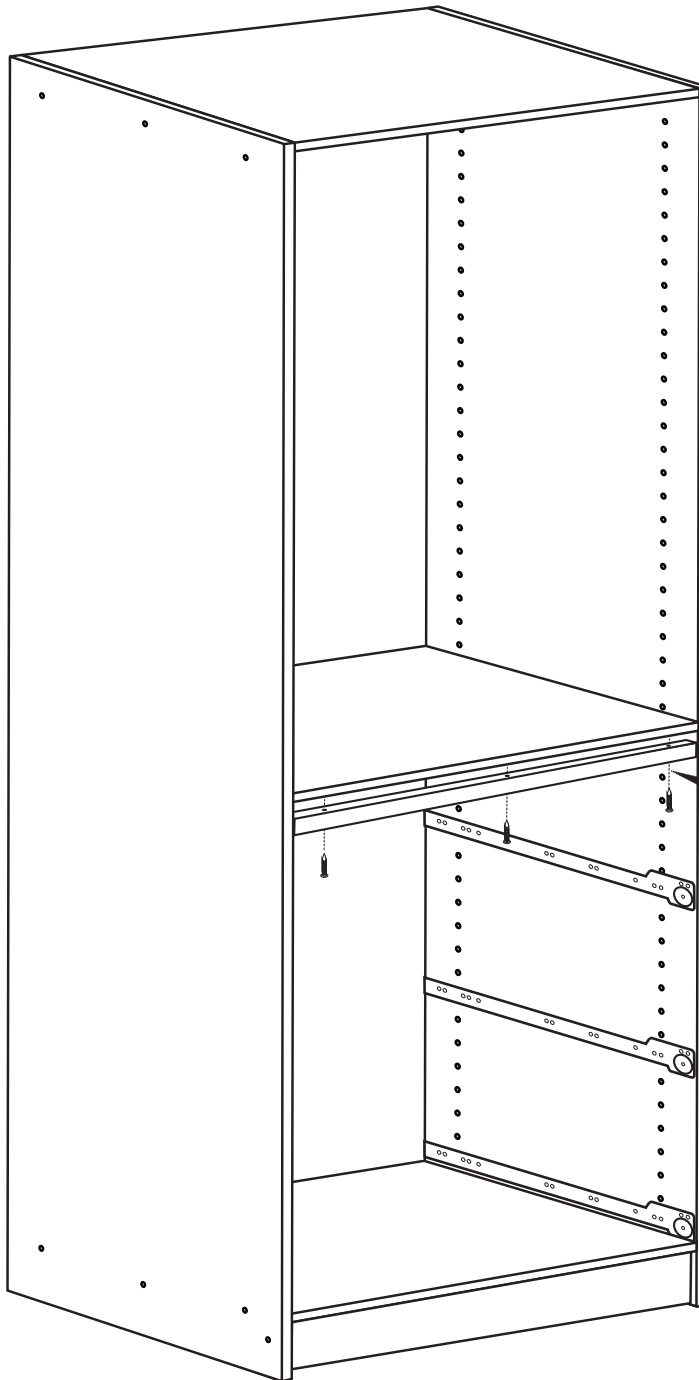
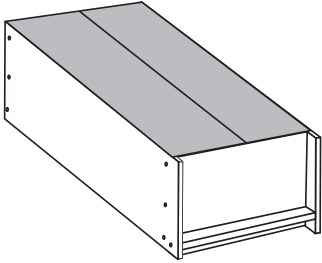



# 8

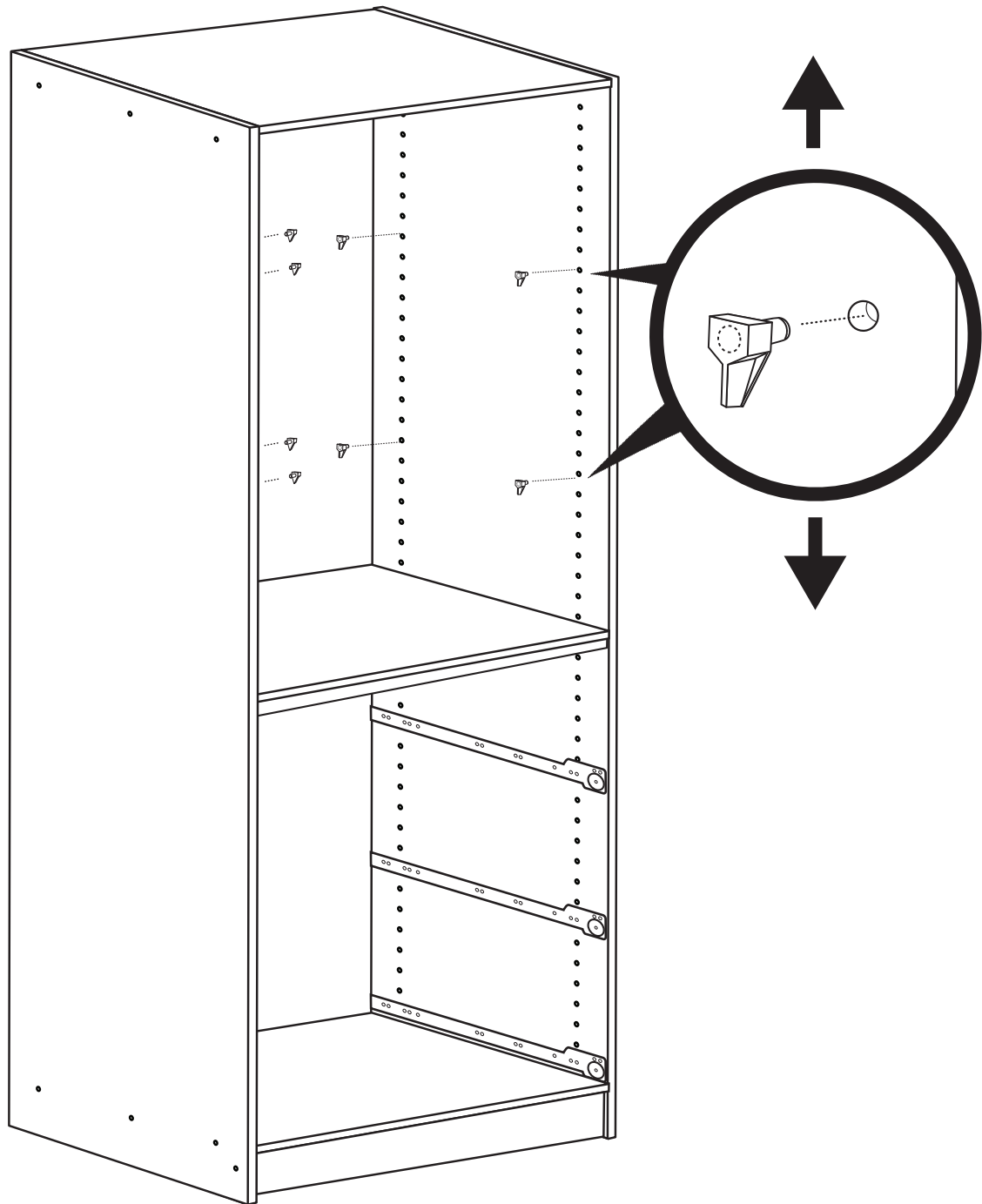

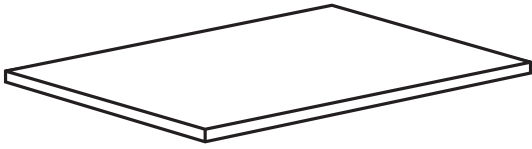

x2

9

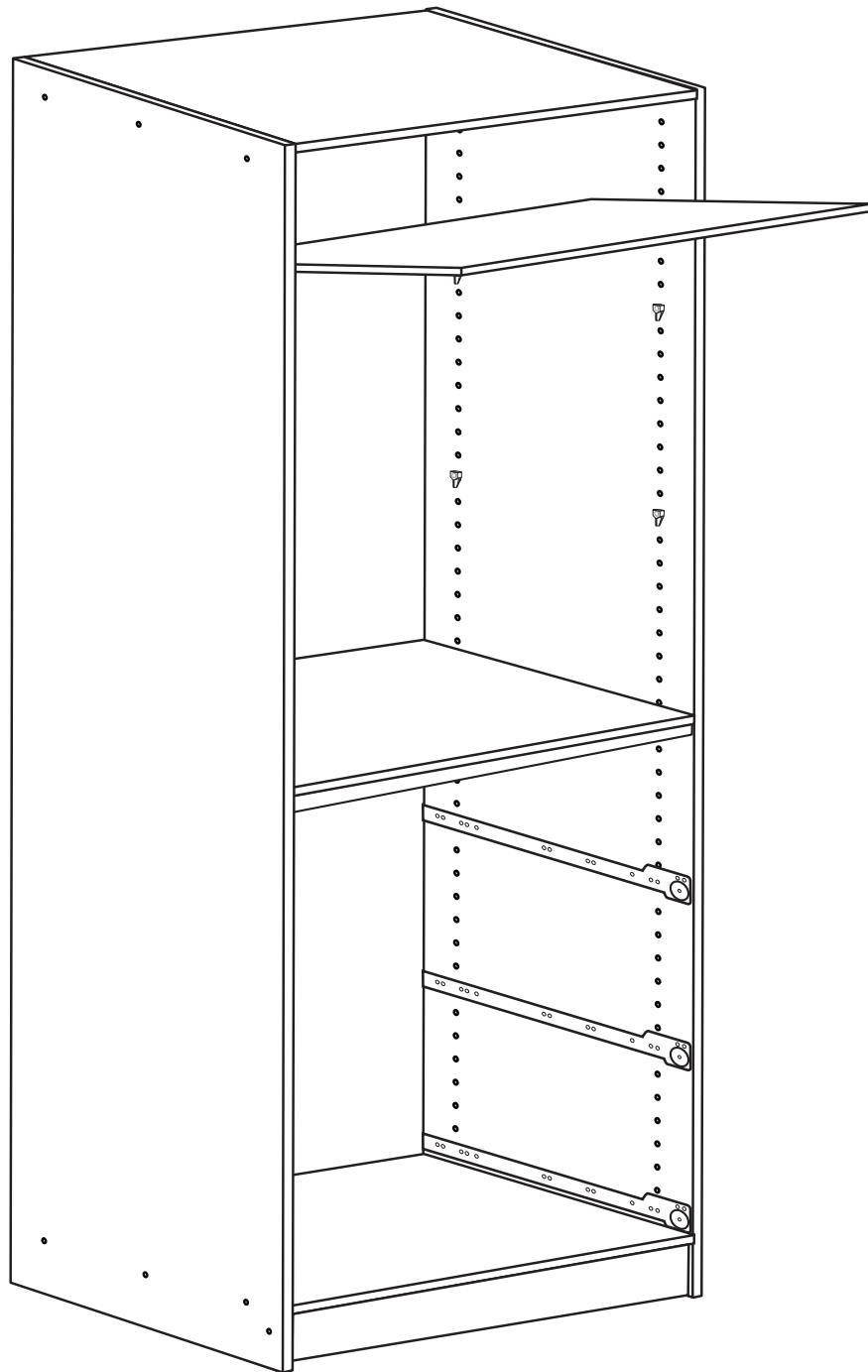

↙  
x2



x4



x2

# 10

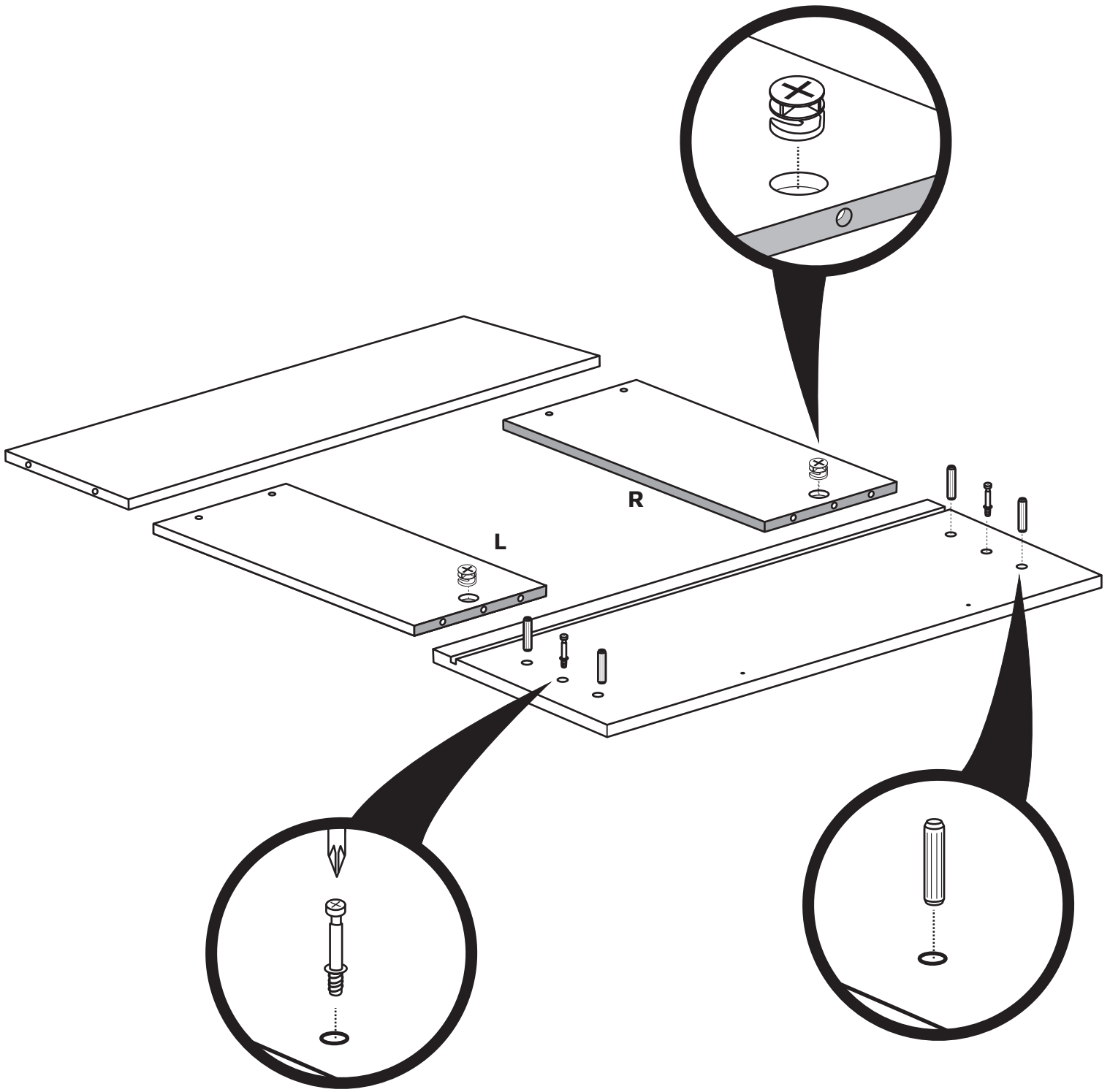

# 11

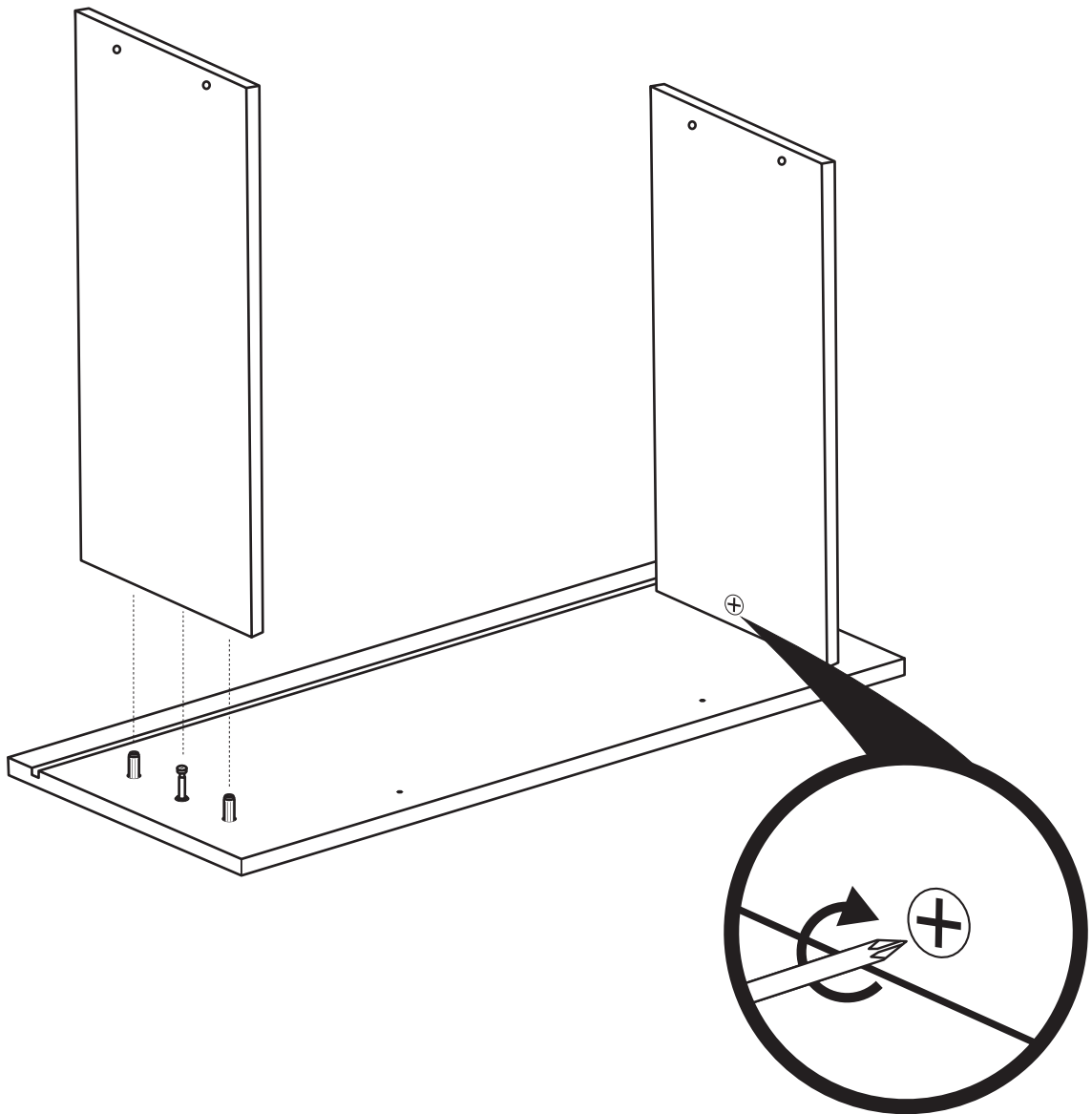

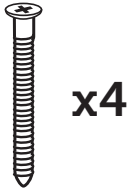

# 12

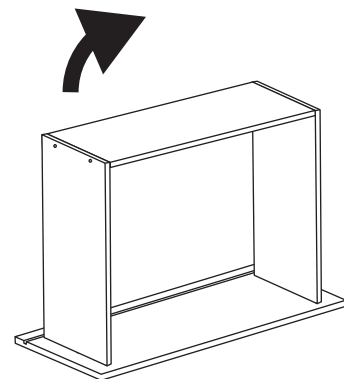
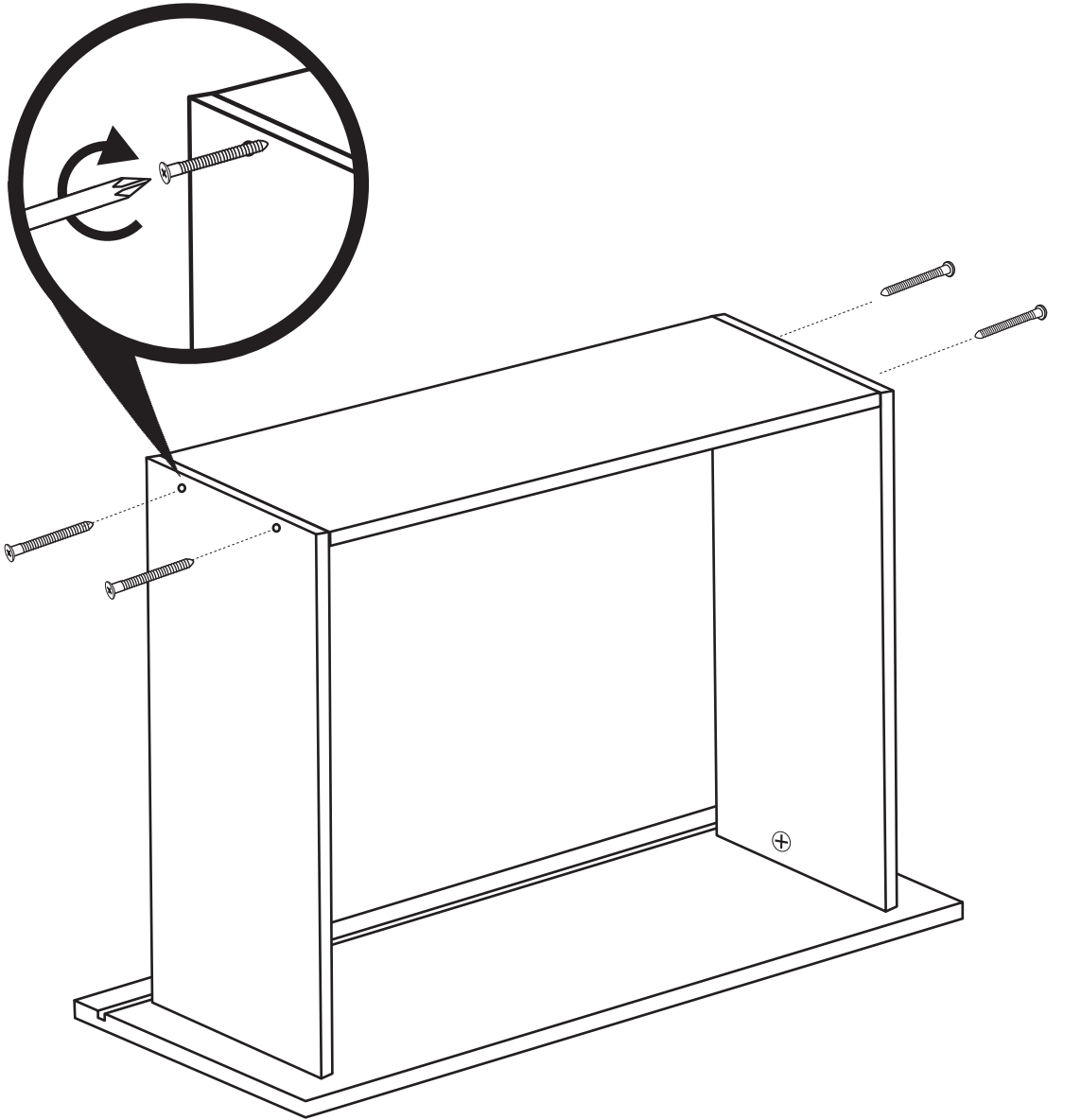



x32

# 13

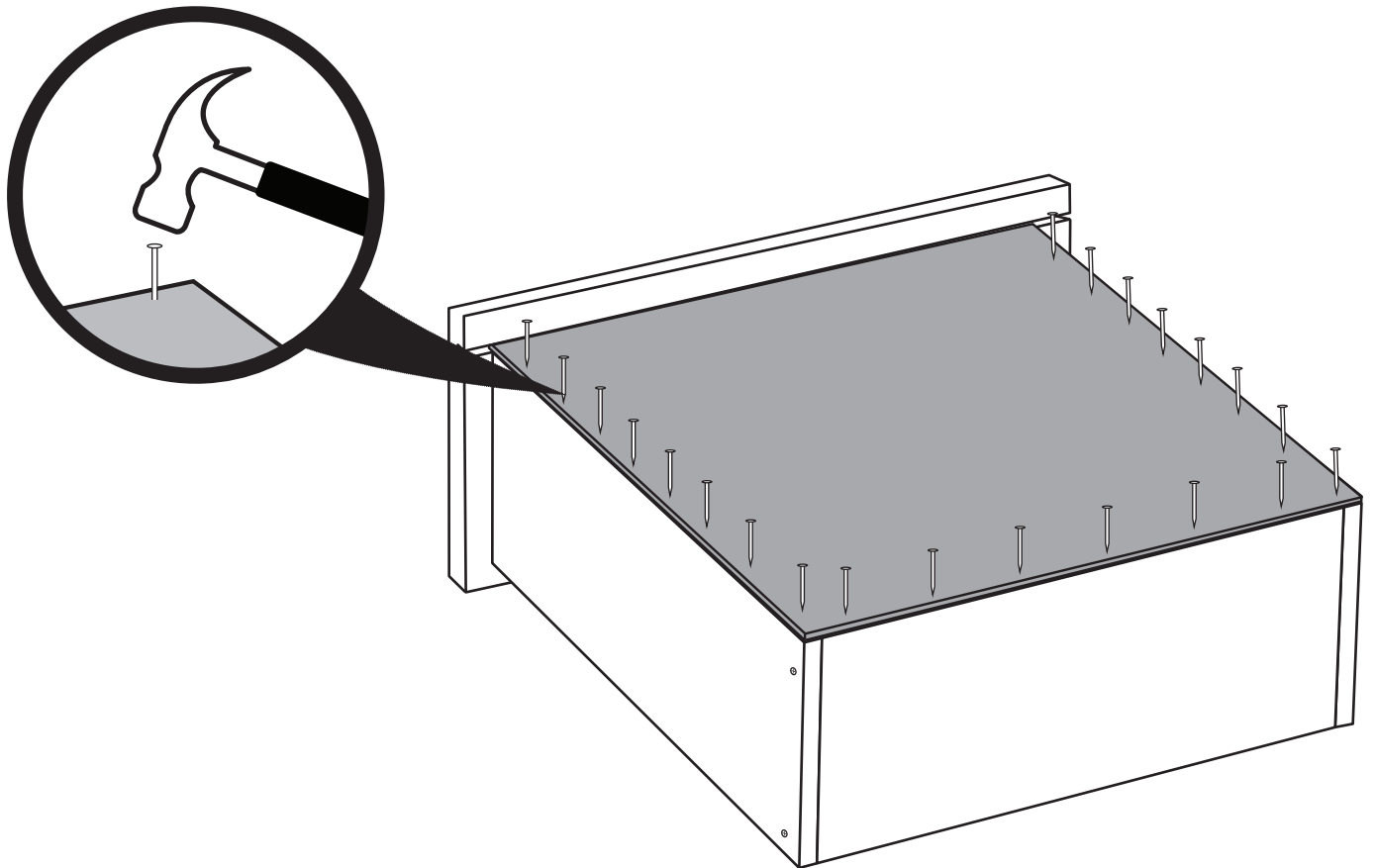
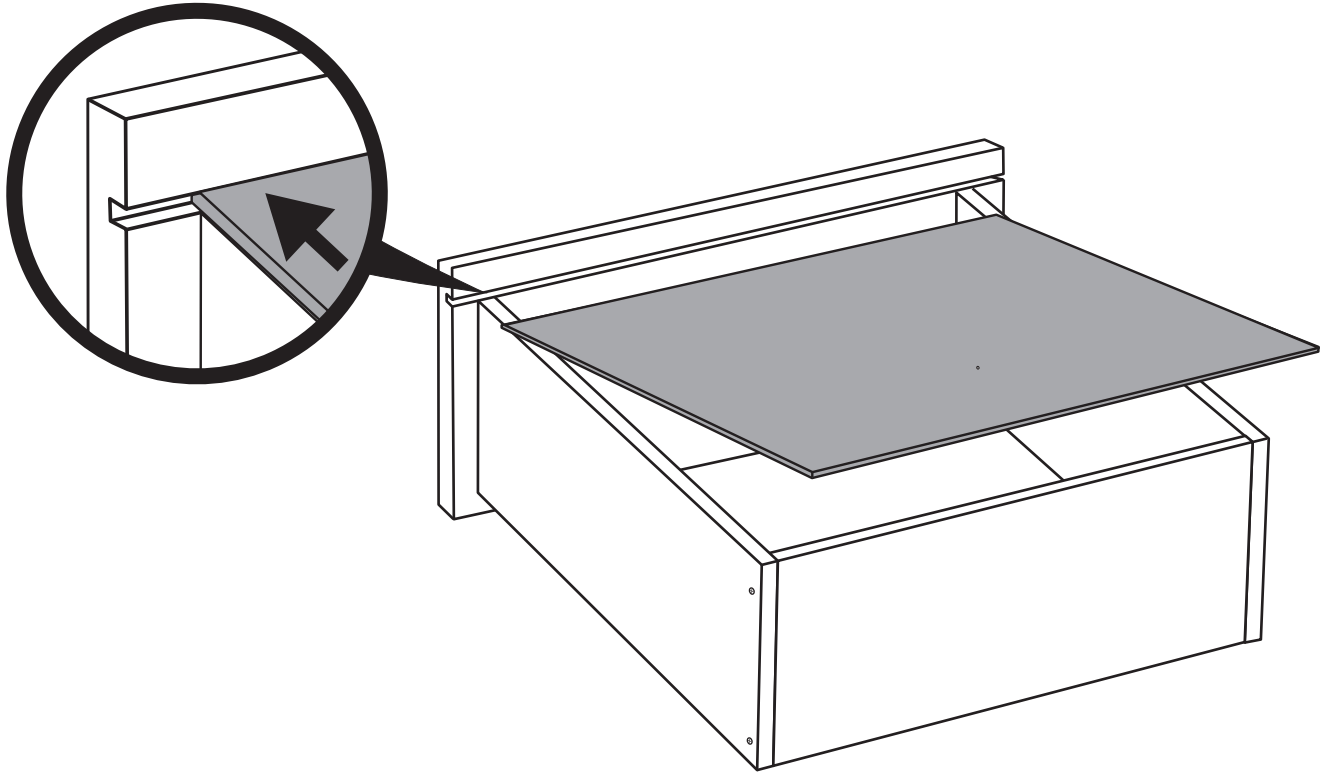



 x4

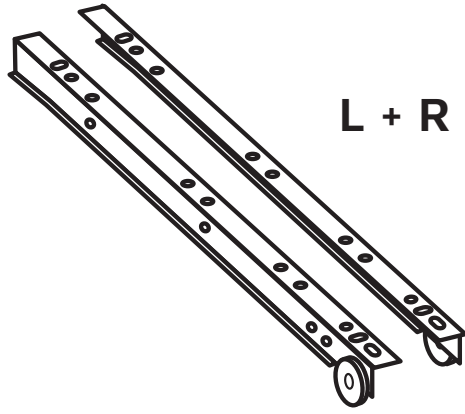

# 14

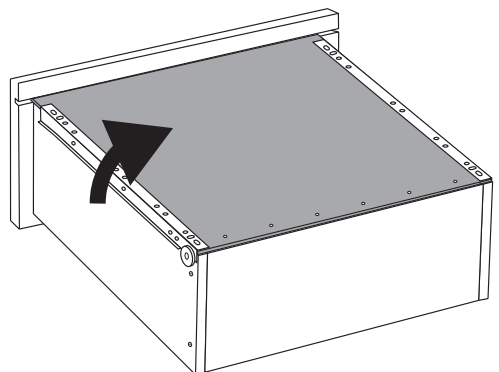
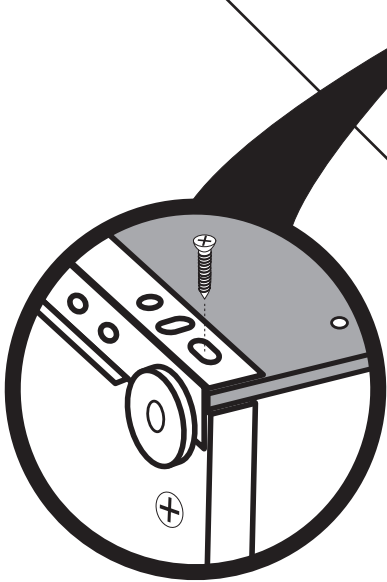
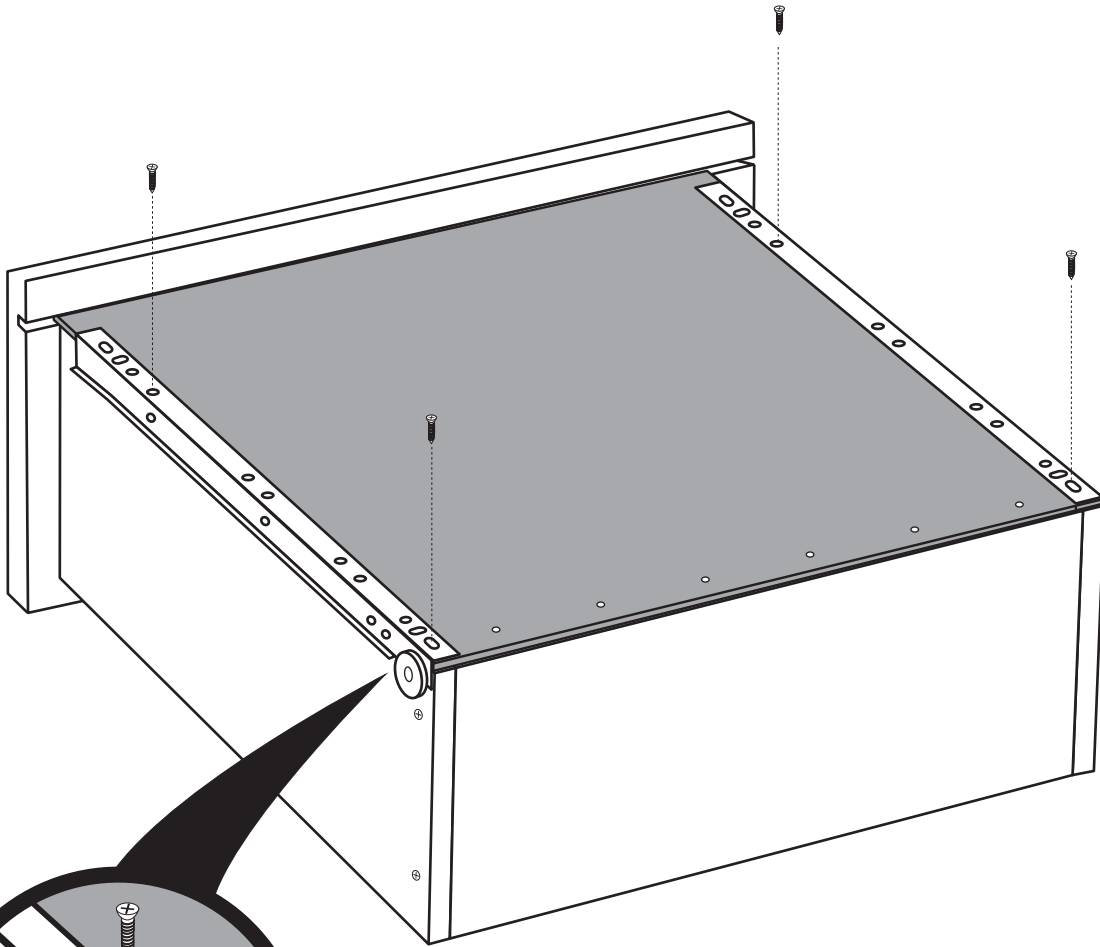

 x2

# 15

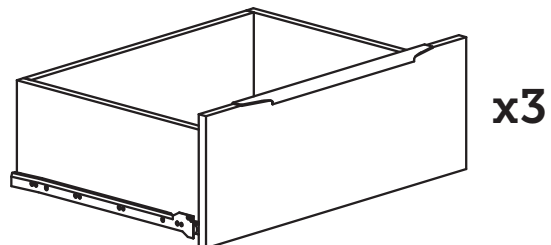
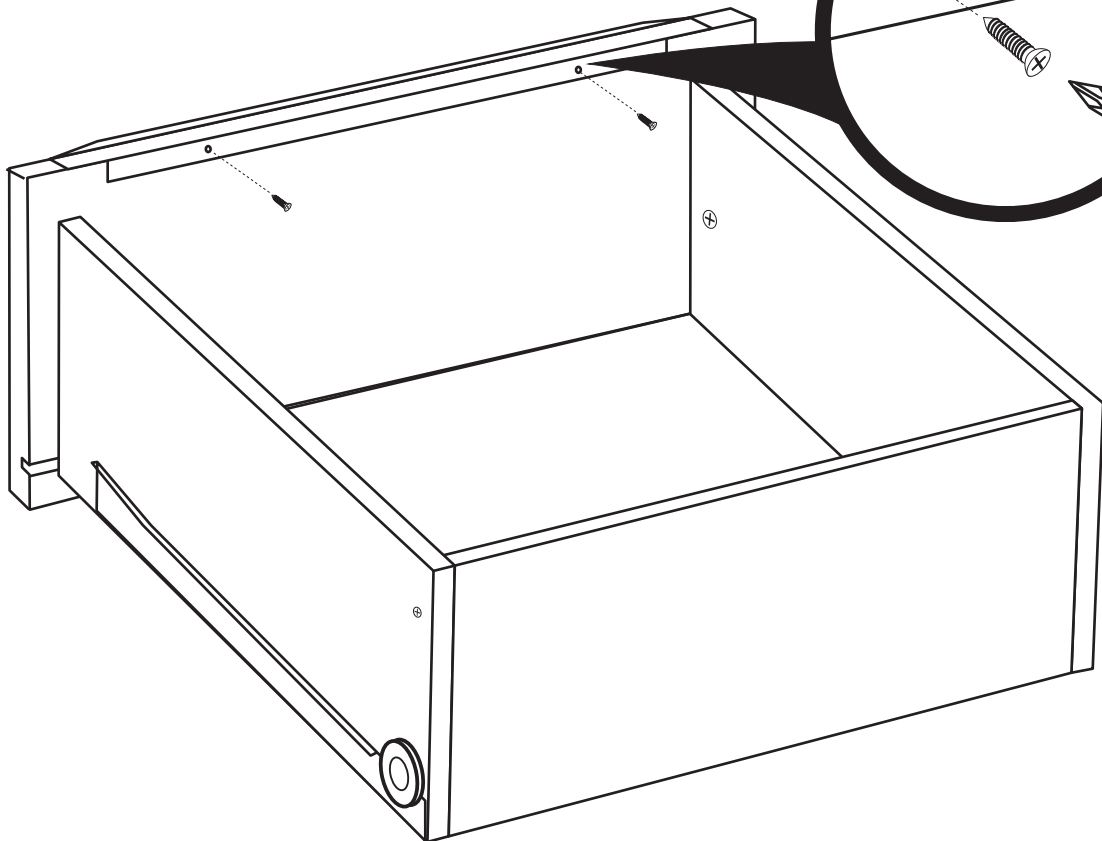
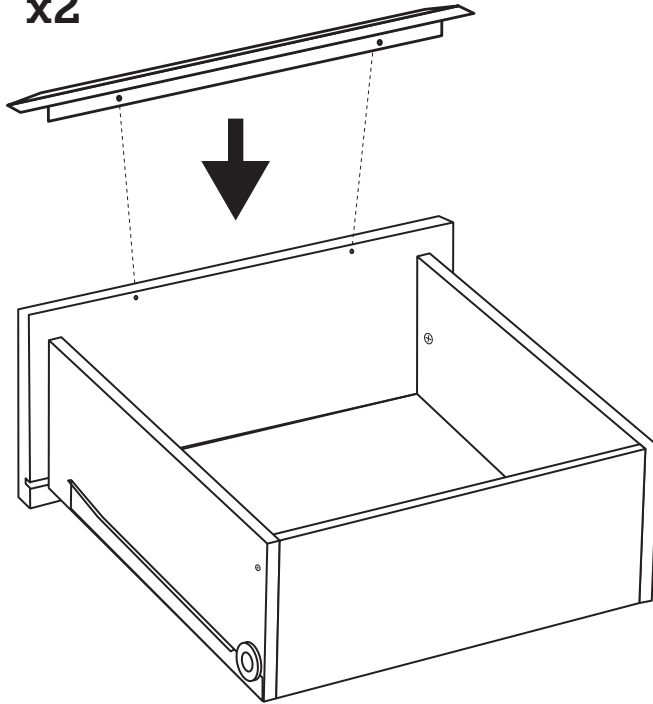

# 16

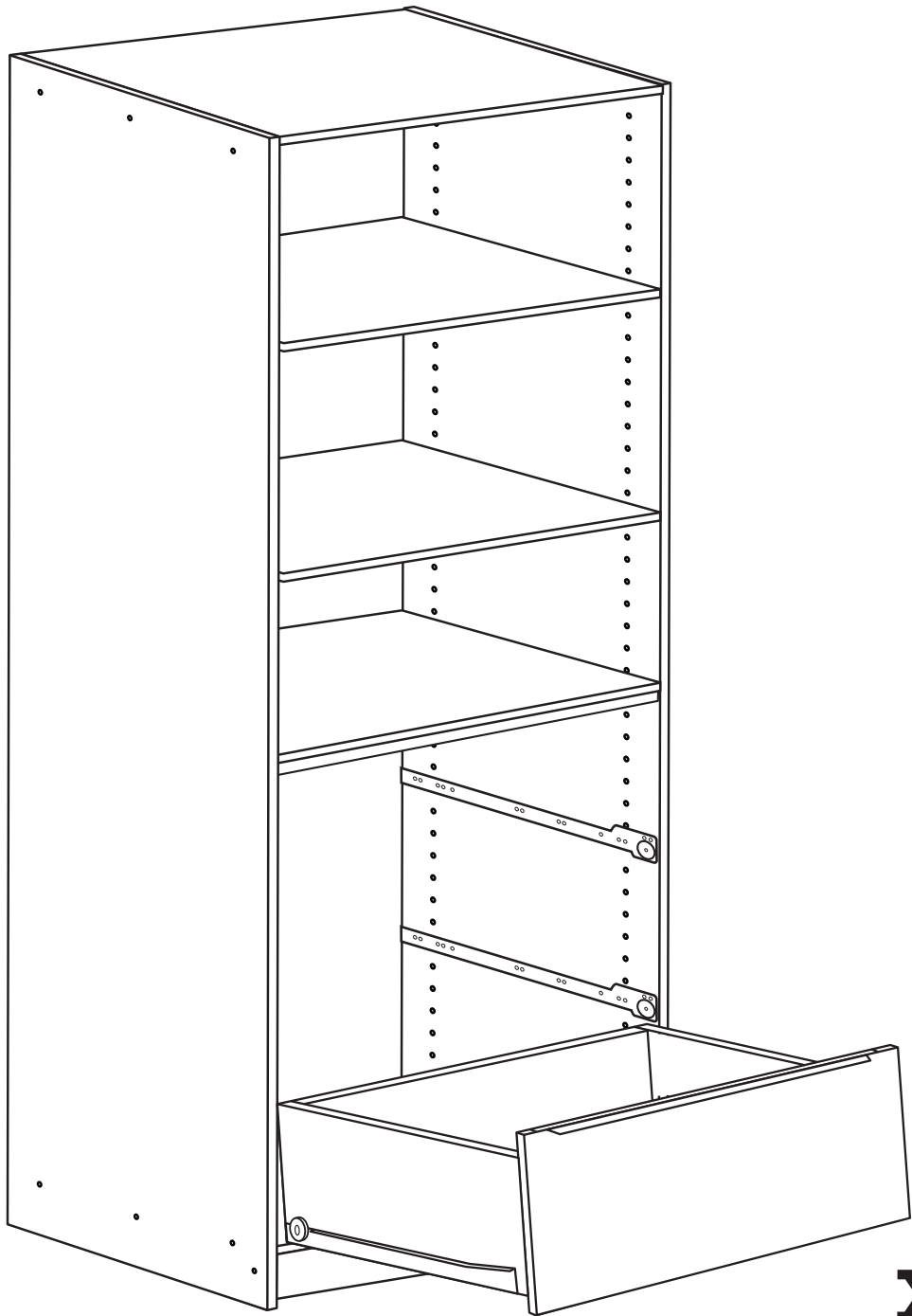

**x3**

# Limited Manufacturer's Warranty for Multistore Solutions Timber Joinery Products

Our goods come with guarantees that cannot be excluded under the Australian Consumer Law. You are entitled to a replacement or refund for a major failure and for compensation for any other reasonably foreseeable loss or damage. You are also entitled to have the goods repaired or replaced if the goods fail to be of acceptable quality and the failure does not amount to a major failure.

## The Warranty

We warrant that the Product is free from defects in workmanship and materials for the Warranty Period.

## What we must do if the Product is Defective

Subject to the conditions of warranty set out in clause 3, if the Product is found to be defective and is returned to the place of purchase at your expense during the Warranty Period, we will repair or replace the Product free of charge.

## What Products are Covered Under the Warranty

This limited warranty applies to domestic use only, and covers defects in material and workmanship in the following components of the Multistore wardrobes and interior organizers

- Frames
- Shelves
- Drawer Boxes
- Doors
- Door Tracks
- Hang Rails

## What Products are Not Covered Under the Warranty

- Drawer Runners
- Hinges
- Wheels
- Guides
- Pull out racks
- Spinning Corner Organiser
- Pull out mirror

## What you must do to Claim Under the Warranty

In order to claim under the Warranty, you must:

- 3.1 Be able to show that the damage or defect has arisen solely from faulty materials or manufacture;
- 3.2 Be able to show that the Product has not been misused, mistreated, damaged or neglected by physical means including but not limited to, fair wear and tear, natural colour variations or fading, faulty installation or damage caused by refitting small replacement items, overloading or movement caused by natural movement of other structures, pests, accidents or acts of God, after purchase;
- 3.3 Be able to show that you have fulfilled your Product Maintenance Obligations;
- 3.4 Be able to show that the Product has not been used, including altered, modified or repaired, in a manner inconsistent with the Prescribed Purpose;
- 3.5 Be able to show that the Product has not at any time been:
  - a. Exposed to excessive heat, moisture, ultra-violet or physical or chemical abuse (such as floor and paint strippers and other harsh or inappropriate cleaning chemicals i.e. bleach);
  - b. Installed in a portable or mobile building or structure, including but not limited to a caravan or boat;
  - c. Re-installed at a location other than the original installation site; or
  - d. Inadequately supported by any structure to which it is installed;

- 3.6 Be able to show that the Product was inspected and accepted within forty-eight (48) hours of the purchase;
- 3.7 Be able to show that you are the original purchaser by production of the original receipt of purchase clearly showing the Date of Purchase;
- 3.8 Pay all transportation charges incurred in returning the defective Product (or parts thereof) for repair, together with the cost of returning them to you.

## Other Important Information in Relation to the Warranty

- 4.1 Our Liability pursuant to this Warranty is (to the extent it is lawful to do so) limited to the cost of repair or replacement of the Product. We shall not in any circumstances be liable for physical or financial injury, loss or damage or for consequential loss or damage of any kind arising from the Product or its use or application by you.
- 4.2 This Warranty is non-transferable and does not apply to any purchaser who bought the product from a reseller or distributor not authorised by us, including but not limited to purchases from internet auction sites or purchases considered as second-hand goods.
- 4.3 Should the Product prove to be irreparable, we reserve the right to substitute an equivalent product if available or to retract the Warranty if no replacement is available.
- 4.4 The benefits provided to you by the Warranty are in addition to other rights and remedies available to you.

## Who is Giving the Warranty?

The entity giving the Warranty is:

Star Business Investments Pty Ltd trading as Multistore Solutions  
ACN 629 598 161  
9 Nevilles Street, Underwood QLD 4119  
Phone: (07) 3208 6799 Email: admin@multistore.com.au

## Definitions

"the Date of Purchase" means the date the Product is purchased and fully paid for from an authorised retailer as evidenced by the properly dated receipt issued to you at the time of purchase on or after 1st July 2019.

"Product Maintenance Obligations" means cleaning the Product with high performance thinners. Although the timber joinery products are defined as moisture resistant, there is a likelihood of some swelling in thickness and change in dimensions if they are exposed to the elements for protracted periods. Care must be taken to avoid excessive amounts of water remaining in contact with your Product and to ensure the Product is not neglected in storage or on site. Harsh or inappropriate cleaning chemicals, i.e. bleach, must never be used to clean your Product.

"the Product" means Multistore Solutions timber joinery products.

"We, Our or Us" means Star Business Investments Pty Ltd trading as Multistore Solutions.

"the Warranty Period" means ten (10) years from the Date of Purchase.

"the Prescribed Purpose" means for use solely and exclusively as a storage unit for personal domestic and household use.

"You" means the purchaser of the Product.